

	operation when directly connected to chimney		operation when connected accumulation mass	
	cupola	hot air exchanger	cupola	adaptor
Energy label	<b>A+</b>	<b>A+</b>	<b>A+</b>	<b>A+</b>
<b>Operating data</b>				
Nominal heat power	7 kW	11 kW	----	----
Efficiency	> 80 %	> 80 %	----	----
Consumption of wood	2,1 kg/h	3,2 kg/h	6 kg	4,8 kg
Total heat output of the burning chamber	----	----	24 kW	17 kW
Mass flow of flue gas	6,5 g/s	8,6 g/s	20 g/s	13 g/s
Required chimney pressure	12 Pa	12 Pa	12 Pa	15 Pa
Required amount of combustion air	25 m <sup>3</sup> /h	30 m <sup>3</sup> /h	60 m <sup>3</sup> /h	60 m <sup>3</sup> /h
<b>Average flue gas temperature</b>				
on the output	214 °C	217 °C	445 °C	385 °C
past 4 m of ceramic accumulation system KMS 300 <sup>1</sup>	----	----	220 °C	----
past accumulation rings (5x acc. ring Ø440mm)	----	----	----	216 °C
<b>Heat distribution</b>				
fireplace insert	70-82 %	70-82 %	40 %	35 %
door glass (single / double)	30 / 18 %	30 / 18 %	30 / 18 %	30 / 18 %
adjoining accumulation mass	----	----	30-42 %	35-47 %
<b>Information for ventilated builds</b>				
Minimal grill area supply / outgoing	700 / 850 cm <sup>2</sup>	950 / 1150 cm <sup>2</sup>	950 / 1150 cm <sup>2</sup>	950 / 1150 cm <sup>2</sup>
Minimum distance from insulated areas / floor	80 / 0 mm		80 / 0 mm	
Reference insulation <sup>2</sup> ceiling / back wall / side wall / floor	120 / 80 / 80 / 0 mm		120 / 80 / 80 / 0 mm	
Calciumsilicate insulation <sup>3</sup> ceiling / back wall / side wall / floor	90 / 60 / 60 / 0 mm		90 / 60 / 60 / 0 mm	
<b>Information for non-ventilated builds (closed grills)</b>				
Minimum radiant area <sup>4</sup>	3,5 m <sup>2</sup>		5 m <sup>2</sup>	
Minimum distance from insulated areas / floor	80 / 20 mm		80 / 20 mm	
Reference insulation <sup>2</sup> ceiling / back wall / side wall / floor	160 / 100 / 100 / 20 mm		160 / 100 / 100 / 20 mm	
Calciumsilicate insulation <sup>3</sup> ceiling / back wall / side wall / floor	120 / 75 / 75 / 20 mm		120 / 75 / 75 / 20 mm	
<b>General technical information</b>				
Total weight / lining weight	ca. 210 / 82 kg		ca. 210 / 82 kg	
Burning chamber dimensions (width x depth)	605 x 305 mm			
Combustion air connection	Ø 150 mm			
Use in non-ventilated accumulation builds according to craft rules	suitable			
Tested according to	EN 13229			
Meets values	1. BlmSchV (Stufe2), 15a BVG			

<sup>1</sup> Listed value from testing. For accurate results is evaluation of each system in the Ortnr / KOV program necessary.

<sup>2</sup> Mineral wool according to AGI-Q 132

<sup>3</sup> Example SkamoEnclousure Board 225 kg/m<sup>3</sup>

<sup>4</sup> Depends on accumulation period and material characteristics. Listed values calculated with chamotte stone thickness 30 mm with radiant area 500 W/m<sup>2</sup>

# HAKA 67/38

Technical data  
Version 2019/08

hot air exchanger 45°

M 1:10

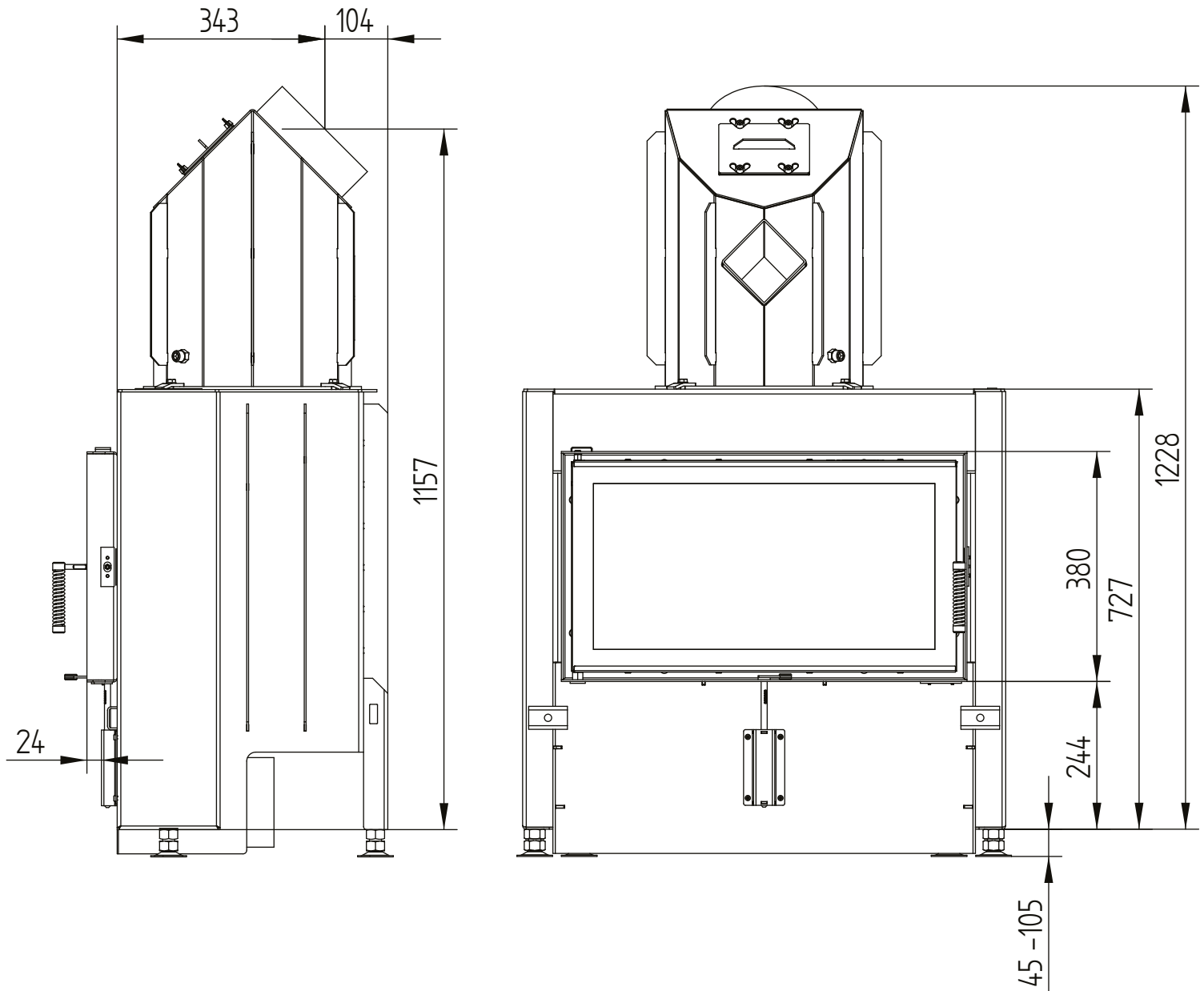

# HAKA 67/38

Technical data  
Version 2019/08

hot air exchanger 45°

M 1:10

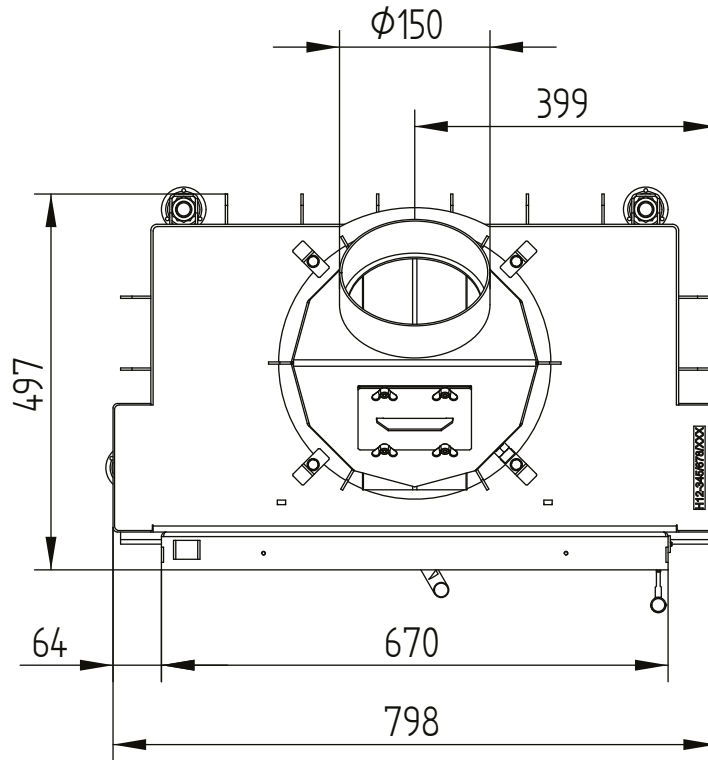

# HAKA 67/38

Technical data  
Version 2019/08

hot air exchanger vertical

M 1:10

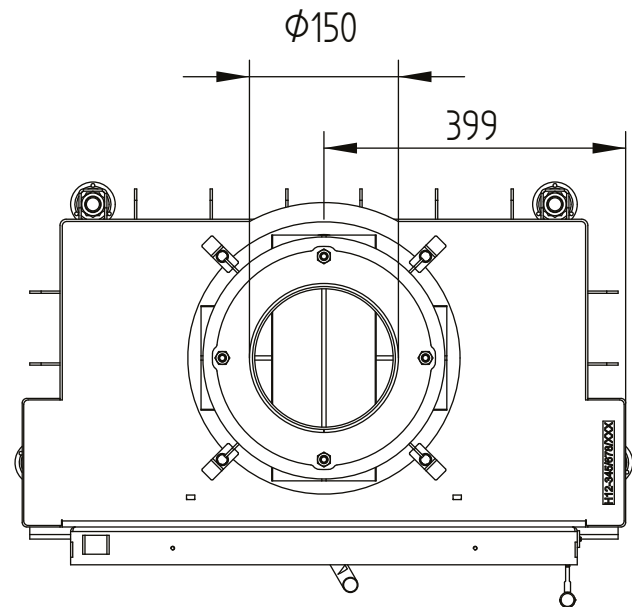
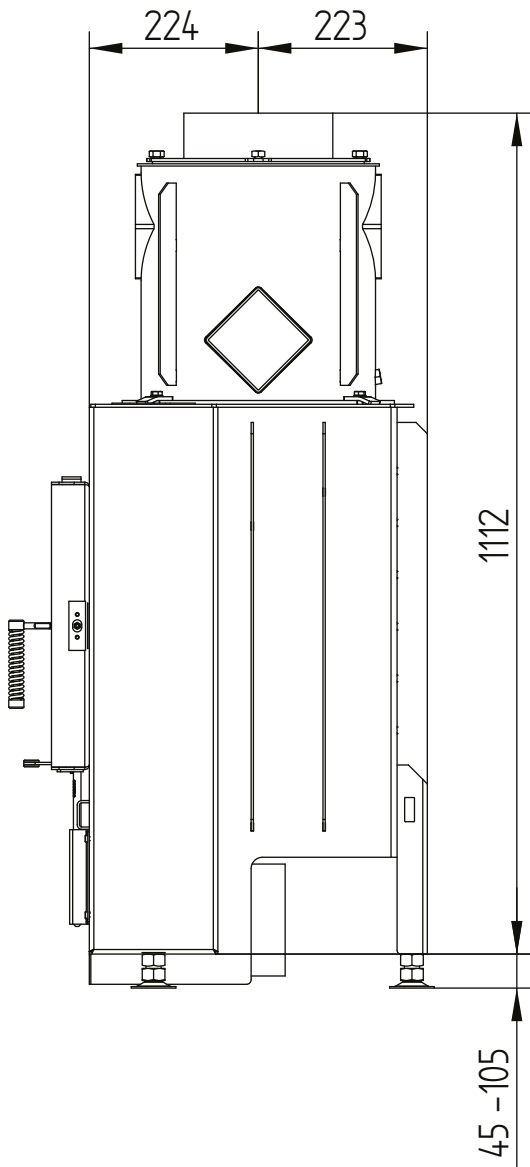

# HAKA 67/38

Technical data  
Version 2019/08

cupola

M 1:10

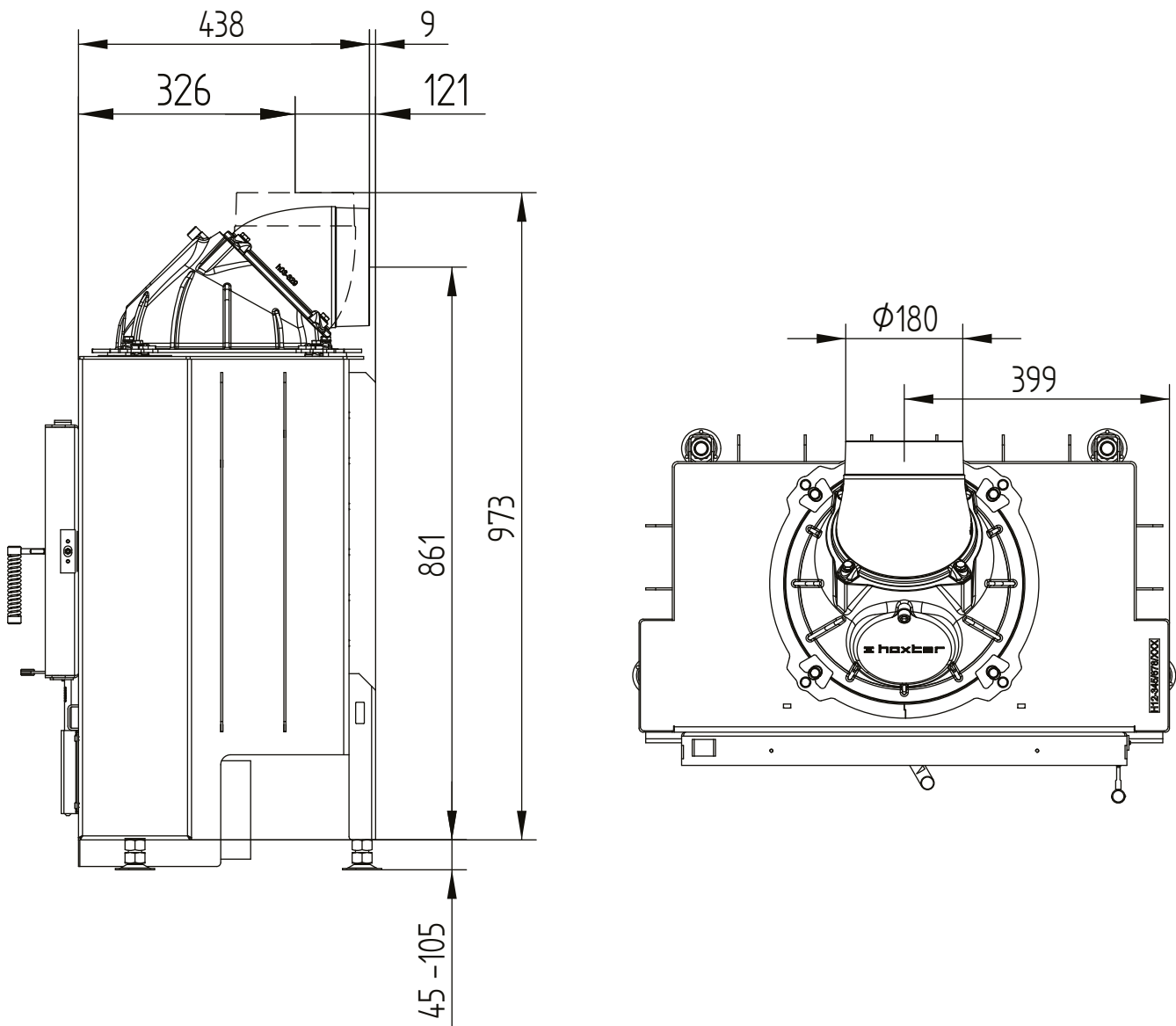

# HAKA 67/38

Technical data  
Version 2019/08

accumulation rings

M 1:10

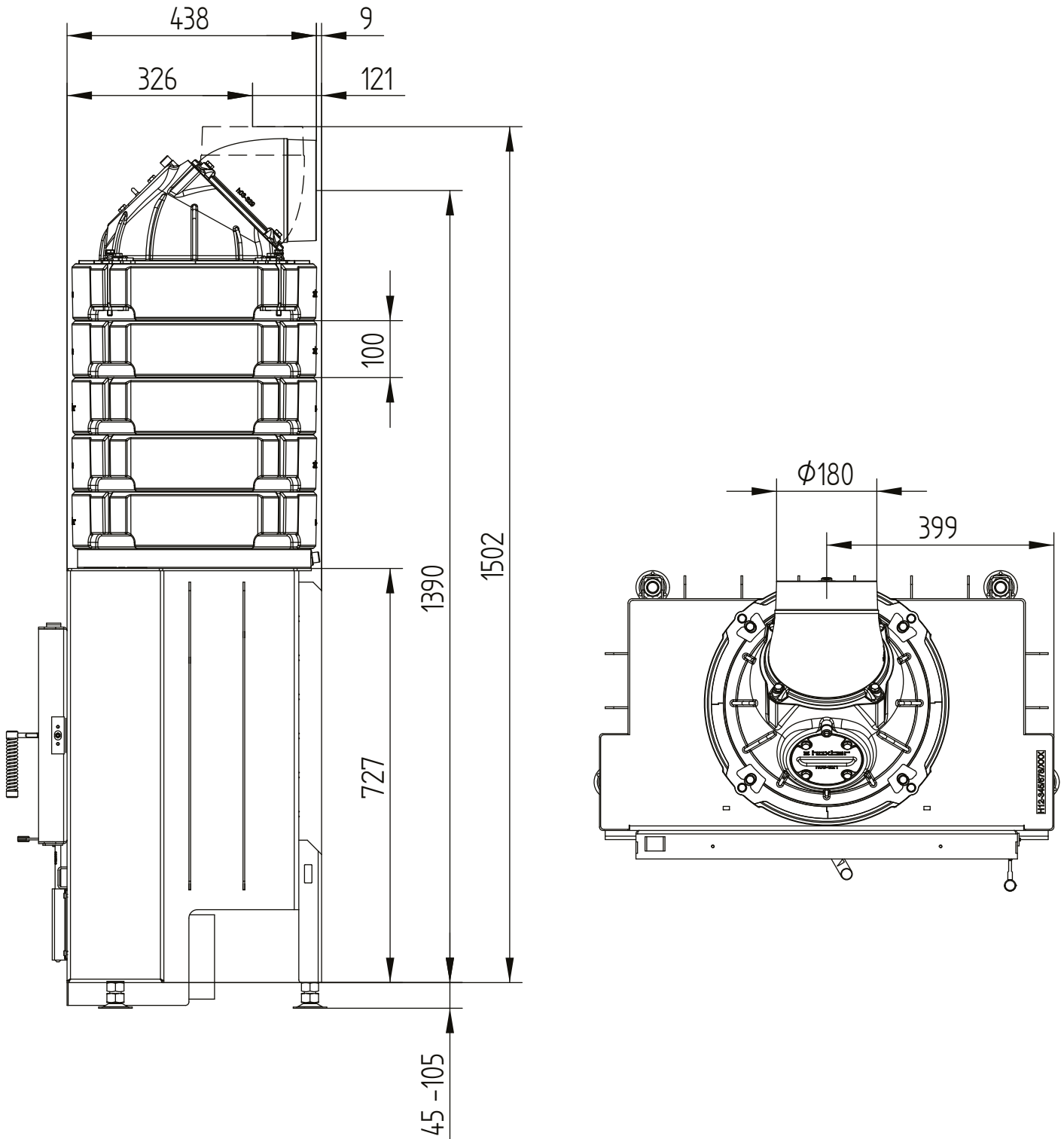

# HAKA 67/38

Technical data  
Version 2019/08

cover frame 67/38 4sides 1 x 90° 50 mm / air intake

M 1:10

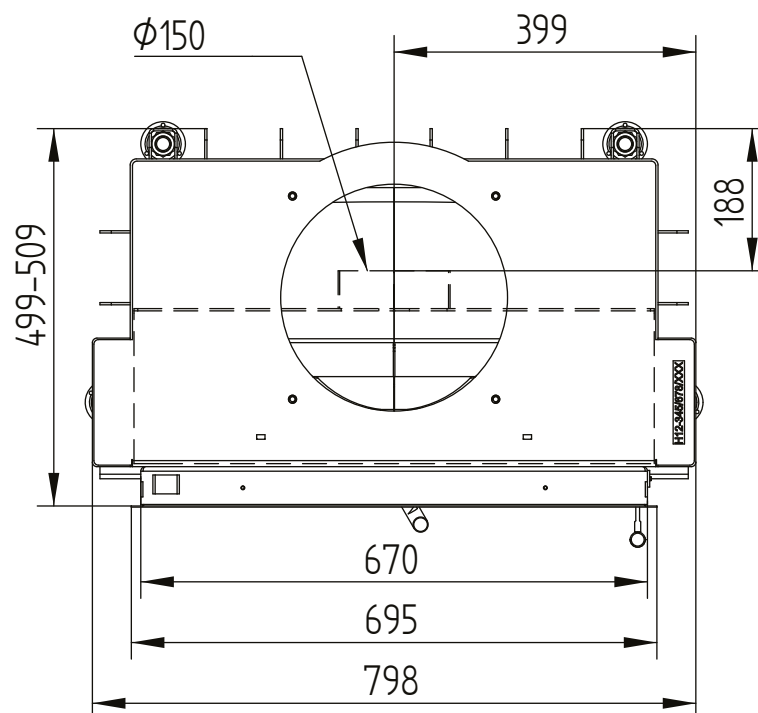
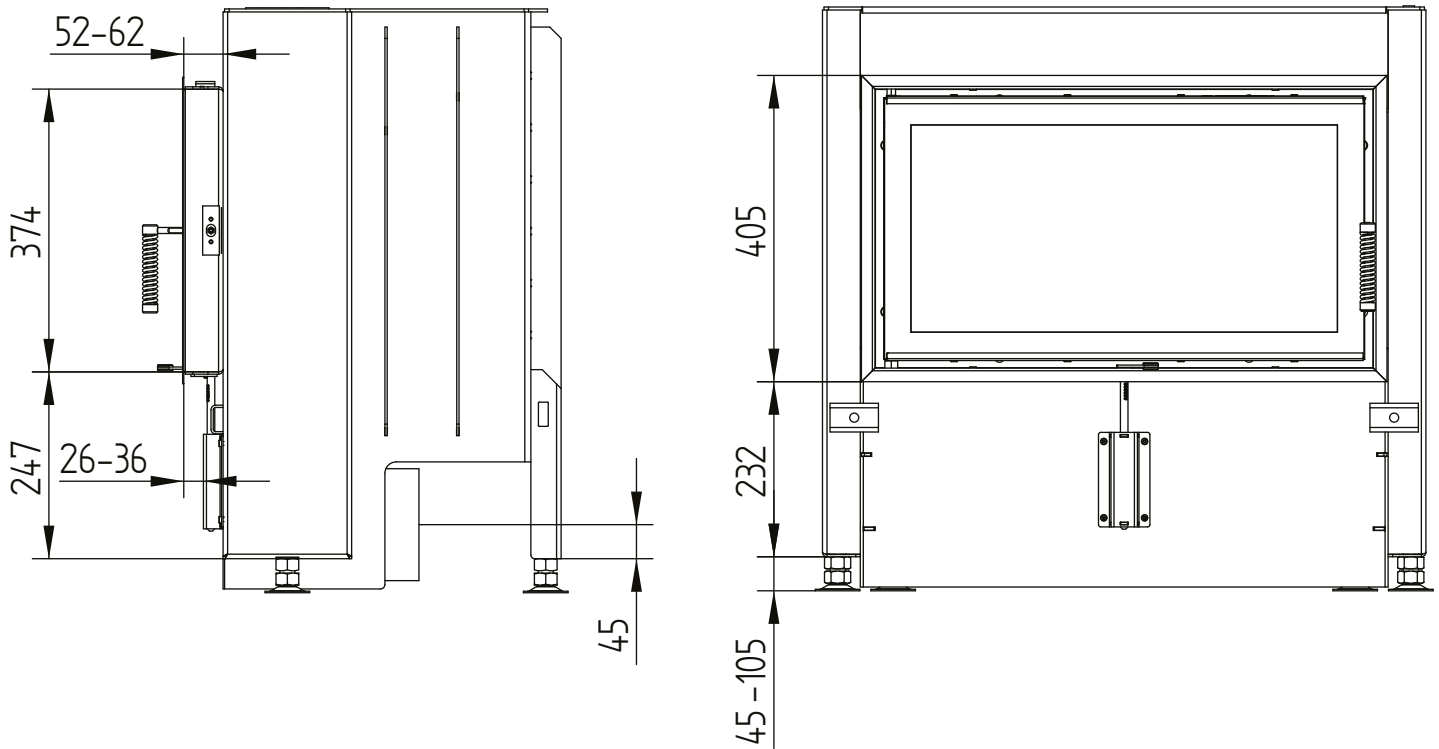

# HAKA 67/38

Technical data  
Version 2019/08

cover frame 67/38 4sides 2 x 45° 80 mm / feet

M 1:10

